

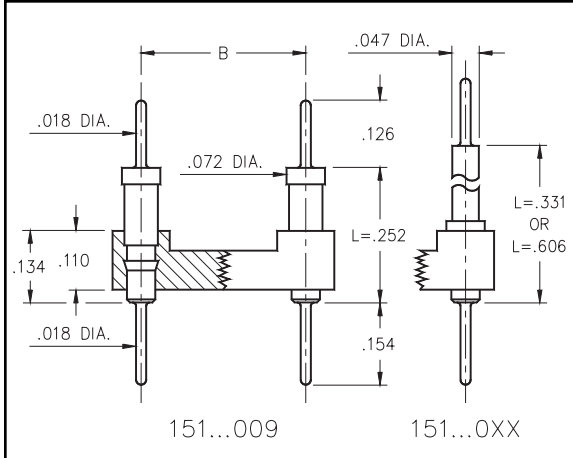

DUAL-IN-LINE PIN HEADERS

Interconnect Open Frame

Series 151...009, 010, 011



- Series 151 DIL Headers use .018" dia. solder tails at both ends make this header entirely pluggable.
- Series:
151...009 use MM #5509 pins
151...010 use MM #5510 pins
151...011 use MM #5511 pins
See pages 170 and 172 for details.
- Insulators are high temperature thermoplastic.

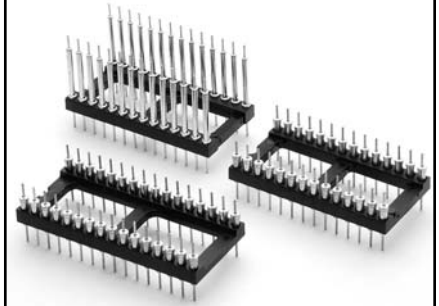

Total number of pins				Quantity per tube	<h3>Ordering Information</h3> <p>XX=Plating Code See Below</p> <p>For RoHS compliance select plating code.</p>			
	A	B	C		L = .252	L = .331	L = .606	
	10	0.5	0.2		0.3	41	151-XX-210-00-009000	151-XX-210-00-010000
4	0.2	0.3	0.4	102	151-XX-304-00-009000	151-XX-304-00-010000	151-XX-304-00-011000	
6	0.3	0.3	0.4	67	151-XX-306-00-009000	151-XX-306-00-010000	151-XX-306-00-011000	
8	0.4	0.3	0.4	50	151-XX-308-00-009000	151-XX-308-00-010000	151-XX-308-00-011000	
10	0.5	0.3	0.4	40	151-XX-310-00-009000	151-XX-310-00-010000	151-XX-310-00-011000	
14	0.7	0.3	0.4	28	151-XX-314-00-009000	151-XX-314-00-010000	151-XX-314-00-011000	
16	0.8	0.3	0.4	25	151-XX-316-00-009000	151-XX-316-00-010000	151-XX-316-00-011000	
18	0.9	0.3	0.4	22	151-XX-318-00-009000	151-XX-318-00-010000	151-XX-318-00-011000	
20	1.0	0.3	0.4	20	151-XX-320-00-009000	151-XX-320-00-010000	151-XX-320-00-011000	
22	1.1	0.3	0.4	18	151-XX-322-00-009000	151-XX-322-00-010000	151-XX-322-00-011000	
24	1.2	0.3	0.4	16	151-XX-324-00-009000	151-XX-324-00-010000	151-XX-324-00-011000	
28	1.4	0.3	0.4	14	151-XX-328-00-009000	151-XX-328-00-010000	151-XX-328-00-011000	
20	1.0	0.4	0.5	20	151-XX-420-00-009000	151-XX-420-00-010000	151-XX-420-00-011000	
22	1.1	0.4	0.5	18	151-XX-422-00-009000	151-XX-422-00-010000	151-XX-422-00-011000	
24	1.2	0.4	0.5	16	151-XX-424-00-009000	151-XX-424-00-010000	151-XX-424-00-011000	
28	1.4	0.4	0.5	14	151-XX-428-00-009000	151-XX-428-00-010000	151-XX-428-00-011000	
32	1.6	0.4	0.5	12	151-XX-432-00-009000	151-XX-432-00-010000	151-XX-432-00-011000	
24	1.2	0.6	0.7	16	151-XX-624-00-009000	151-XX-624-00-010000	151-XX-624-00-011000	
28	1.4	0.6	0.7	14	151-XX-628-00-009000	151-XX-628-00-010000	151-XX-628-00-011000	
32	1.6	0.6	0.7	12	151-XX-632-00-009000	151-XX-632-00-010000	151-XX-632-00-011000	
36	1.8	0.6	0.7	11	151-XX-636-00-009000	151-XX-636-00-010000	151-XX-636-00-011000	
40	2.0	0.6	0.7	10	151-XX-640-00-009000	151-XX-640-00-010000	151-XX-640-00-011000	
42	2.1	0.6	0.7	9	151-XX-642-00-009000	151-XX-642-00-010000	151-XX-642-00-011000	
48	2.4	0.6	0.7	8	151-XX-648-00-009000	151-XX-648-00-010000	151-XX-648-00-011000	
50	2.5	0.6	0.7	8	151-XX-650-00-009000	151-XX-650-00-010000	151-XX-650-00-011000	
52	2.6	0.6	0.7	7	151-XX-652-00-009000	151-XX-652-00-010000	151-XX-652-00-011000	
50	2.5	0.9	1.0	8	151-XX-950-00-009000	151-XX-950-00-010000	151-XX-950-00-011000	
52	2.6	0.9	1.0	7	151-XX-952-00-009000	151-XX-952-00-010000	151-XX-952-00-011000	
64	3.2	0.9	1.0	6	151-XX-964-00-009000	151-XX-964-00-010000	151-XX-964-00-011000	
SPECIFY PLATING CODE XX=					10	90	40	
Pin Plating					10μ" Au	200μ" Sn/Pb	200μ" Sn	